

Porcupine - POA Series

The **RJH ACETI PORCUPINE Wire Brush Machine** is a robust machine that is ideal for deburring pipes, profiles, flat bar and sheet metal. The Porcupine complies with the European Machinery Directive. All RJH industrial machines carry a 12 month warranty and are supplied with an operating manual.

KEY FEATURES

- Single and double-ended models available
- Adjustable height work rests
- Fabricated base
- Tool cupboard in pedestal
- Suitable for use with wire brushes, fan wheels, mops or grinding wheels
- Supplied with two steel wire brushes. Stainless steel brushes can be purchased separately – please contact our sales office for more information

SAFETY FEATURES

- Motor braking system
- No-volt overload push-button controls
- Emergency stop
- Adjustable guards
- Dust extraction spigots – 80mm outside diameter
- Eye shields
- Low noise level

OPTIONAL REFINEMENTS

- Flexible LED Floodlight*
- Standard or heavy duty foot stop (POA92)*
- Heavy duty foot stop (POA81)*
- Dust extraction to enable compliance with UK COSHH regulations*

*Please note that these items are factory fitted at the point of manufacture



Porcupine, POA81



Porcupine, POA92



Guarding



Twin Speed Electric Controls

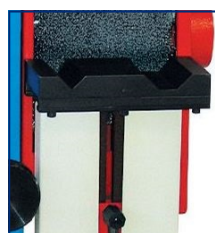

Work Rest



Optional Standard Foot Stop



Optional Heavy Duty Foot Stop

Porcupine - POA Series - continued..

Specification:

MODEL	POA81	POA92
Motor	4.4kw	4.4kw
Motor Speed	1400 & 2800rpm	1400 & 2800rpm
Electrical Supply	400V/3ph/50Hz	
Maximum Brush Size (LHS), dia x width	250 x 60mm	250 x 60mm
Maximum Brush Size (RHS), dia x width	250 x 120mm	N/A
Spindle Diameter	100mm	100mm
Wire Brush Speed	18 & 36m/sec	18 & 36m/sec
Noise Level	75dB	75dB
HD Bolt Centres	500 CRS to suit 2–8mm Bolts	
Weight	180kg	155kg

Dimensions:

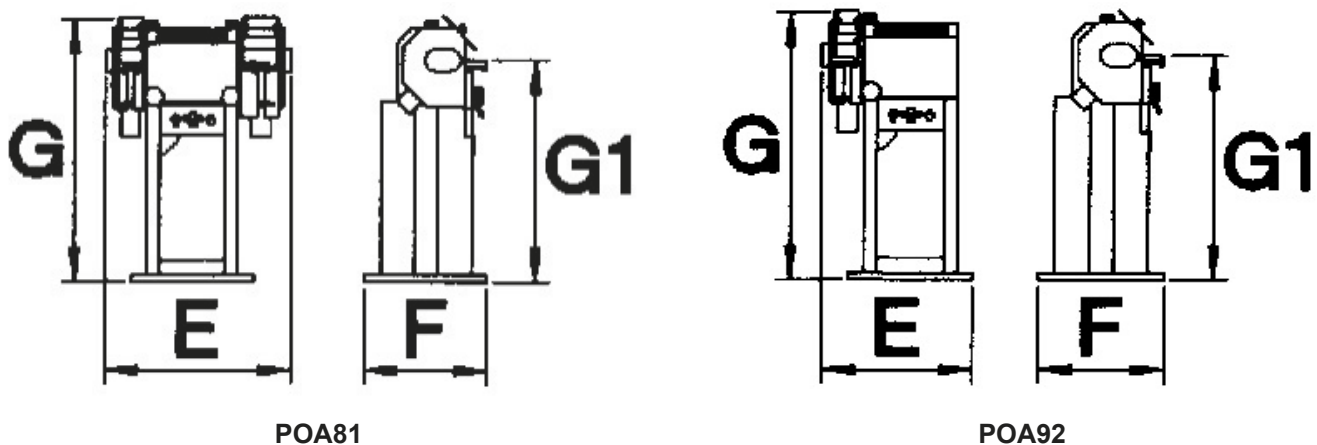

Dimensions, mm	E	F	G	G1
POA81	850	540	1150	960
POA92	670	540	1150	860